

Sipariş Kodu / Ordering Code

KRA C M 50 180 S

Manyetik / Magnet

Dönüş Derecesi / Rotation Angle

Çap / Bore Size (mm)

M:Mil Tipi / Rod Type

C:Derece Ayarlı / Rotation Adjusted

Model / Model

Mil Tipi / Rod Type

M Erkek Pinyon Millî / Male pinion
F Dişi Pinyon Millî / Female pinion

C:Derece Ayarlı / Rotation Adjusted

C Ayarlanabilir derece ayarı (+ - 10 / 15) / Adjustable degree
- Derece ayarı yoktur / No adjustable degree

Çap / Bore Size (mm)

025 - 032 - 040 - 050 - 063 - 080 - 100 - 125 mm

Dönüş Derecesi / Rotation Angle

90° - 180° - 270° - 360°

Manyetik / Magnet

S Manyetik / Magnetic version
- Manyetik Yok / No Magnetic

Çap / Bore	32	40	50	63	80	100	125
Akışkan / Fluid	Hava / Air						
Çalışma Basınç Aralığı / Working Pressure Range	1 ~ 9,0 kgf/cm ²						
Maximum Basınç Dayanımı / Max. Pressure Resistance	13,5 kgf/cm ²						
Çalışma Sıcaklık Aralığı / Working Temperature Range	0 ~ 70 °C						
Çalışma Hız Aralığı / Working Speed Range	50 ~ 800 mm/sec						
Bağlantı Ölçüsü / Connection Measure	G 1/8	G 1/4	G 1/4	G 3/8	G 3/8	G 1/2	G 1/2

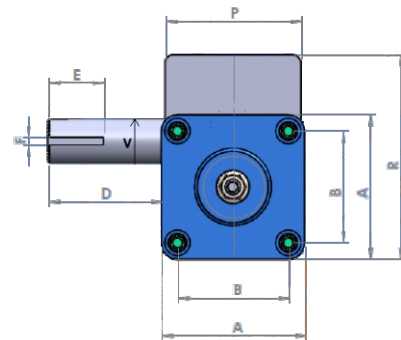
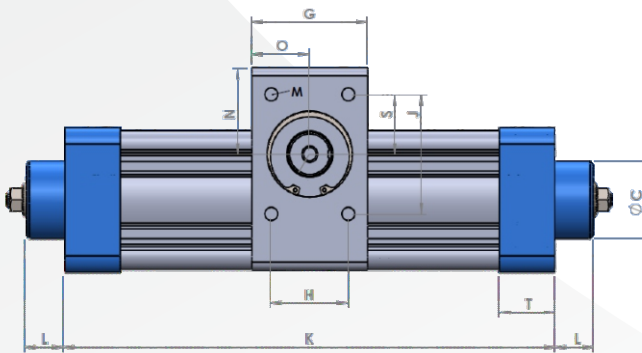
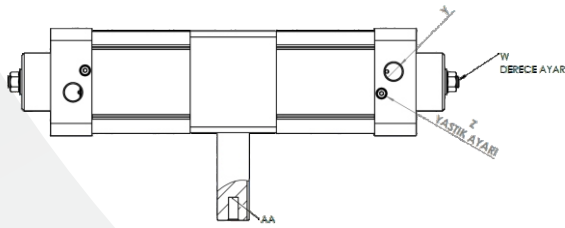

Çap Bore (mm)	A	B	ØC	D	E	F	G	H	J	K	L	ØM	N	O	P	R	S	T	AA	ØV	Y	ØW	ØZ
80	93	72	50	40	20	5	75	34	77	318	25	M10	55.5	37.5	88	130	38.5	36	M10 - 20	28	G 3/8	6	3

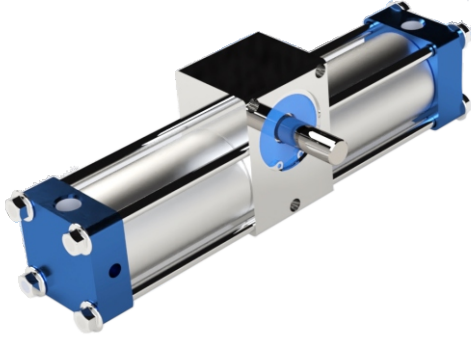

Sipariş Kodu / Ordering Code

KRA F 50 180 S

Manyetik / Magnet
Dönüş Derecesi / Rotation Angle
Çap / Bore Size (mm)
Mil Tipi / Rod Type
Model / Model

Mil Tipi / Rod Type

- M Erkek Pinyon Millî / Male pinion
- F Dişi Pinyon Millî / Female pinion

C:Derece Ayarlı / Rotation Adjusted

- C Ayarlanabilir derece ayarı (+ - 10 / 15) / Adjustable degree
- Derece ayarı yoktur / No adjustable degree

Çap / Bore Size (mm)

025 - 032 - 040 - 050 - 063 - 080 - 100 - 125 mm

Dönüş Derecesi / Rotation Angle

90° - 180° - 270° - 360°

Manyetik / Magnet

- S Manyetik / Magnetic version
- Manyetik Yok / No Magnetic

Çap / Bore	32	40	50	63	80	100	125
Akışkan / Fluid	Hava / Air						
Çalışma Basınç Aralığı / Working Pressure Range	1 ~ 9,0 kgf/cm ²						
Maximum Basınç Dayanımı / Max. Pressure Resistance	13,5 kgf/cm ²						
Çalışma Sıcaklık Aralığı / Working Temperature Range	0 ~ 70 °C						
Çalışma Hız Aralığı / Working Speed Range	50 ~ 800 mm/sec						
Bağlantı Ölçüsü / Connection Measure	G 1/8	G 1/4	G 1/4	G 3/8	G 3/8	G 1/2	G 1/2

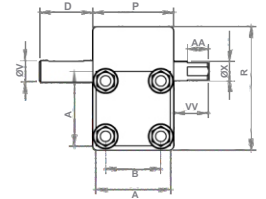
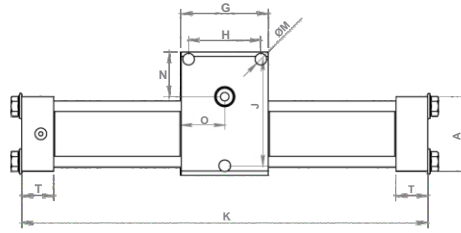
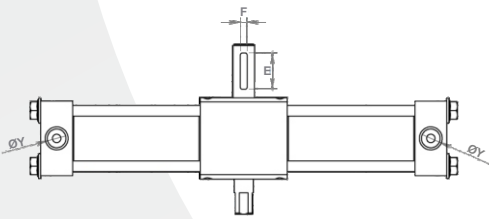

Çap Bore (mm)	A	B	D	E	F	G	H	J	K	ØM	N	O	P	R	T	AA	ØV	VV	ØX	Y
25	35	26	25	15	3	45	34	50	191	5.5	21	20.5	38	58	15	8 - 9.5	12	16.5	9	G 1/8
32	40	32	25	15	3	45	34	50	191	5.5	21	20.5	38	58	15	8 - 9.5	12	16.5	9	G 1/8
40	56	38	25	15	3	59	34	50	291	8.5	21	20.5	38	58	30	8 - 9.5	16	16.5	9	G 1/4
50	40	32	30	15	3	75	34	50	415	5.5	21	20.5	38	58	15	8 - 9.5	20	16.5	9	G 1/4
63	76	56.5	35	20	5	75	34	50	427	8.5	53.5	37.5	75	120	36	-	25	-	-	G 3/8
80	93	72	40	20	5	75	34	77	318	10	55.5	37.5	88	130	36	-	28	-	-	G 3/8

NOKTA YÜKÜ

POINT LOAD

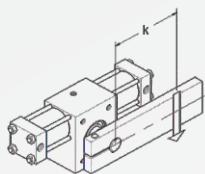

$$J_m = \frac{W}{g} \times k^2$$

KATI KÜRE

SOLID SPHERE

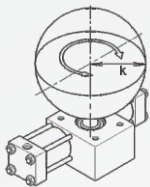

$$J_m = \frac{2}{5} \times \frac{W}{g} \times k^2$$

İNCE DİSK

THIN DISK

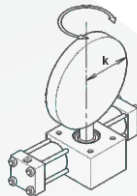

$$J_m = \frac{W}{g} \times \frac{k^2}{4}$$

İNCE DİKDÖRTGEN LEVHA

THIN RECTANGULAR PLATE

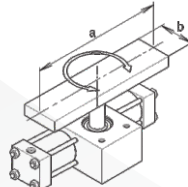

$$J_m = \frac{W}{g} \times \frac{a^2 + b^2}{12}$$

İNCE DİKDÖRTGEN LEVHA

THIN RECTANGULAR PLATE

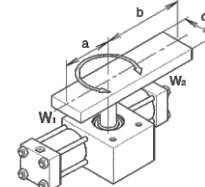

$$J_m = \frac{W_1}{g} \times \frac{4a^2 + c^2}{12} + \frac{W_2}{g} \times \frac{4b^2 + c^2}{12}$$

İNCE ÇUBUK

SLENDER ROD

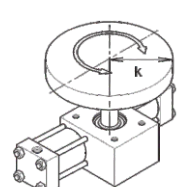

$$J_m = \frac{W}{g} \times \frac{k^2}{2}$$

KİNETİK ENERJİ TEMEL FORMÜLÜ

KINETIC ENERGY BASIC FORMULA

$$KE = 1/2 J_m \omega^2$$

$$\omega = 0,035 \times \frac{\text{DÖNME ZAMANI (saniye)}}{\text{DÖNME AÇISI (derece)}}$$

KE = Kinetik Enerji
 Jm = Rotasyonel kütle atalet momenti
 (Nesnenin fiziksel boyutuna ve ağırlığına bağlıdır.)
 ω = Tepe Hızı (Rad/sn.) (Ortalamanın iki katı hız varsayarak.)
 W = Yük Ağırlığı (lb)
 g = Yerçekimi Sabiti = 386.4 in/sec²
 k = Dönme Yarıçapı (İçinde)

KE = Kinetic Energy
 Jm = Rotational mass moment of inertia (in-lb-sec²)
 (Dependent on physical size of object and weight.)
 ω = Peak Velocity (rad/sec) (Assuming twice average velocity.)
 W = Weight of load (lb)
 g = Gravitational constant = 386.4 in/sec²
 k = Radius of gyration (in)